

GRADERIA TELESCOPICA PARA INTERIOR.

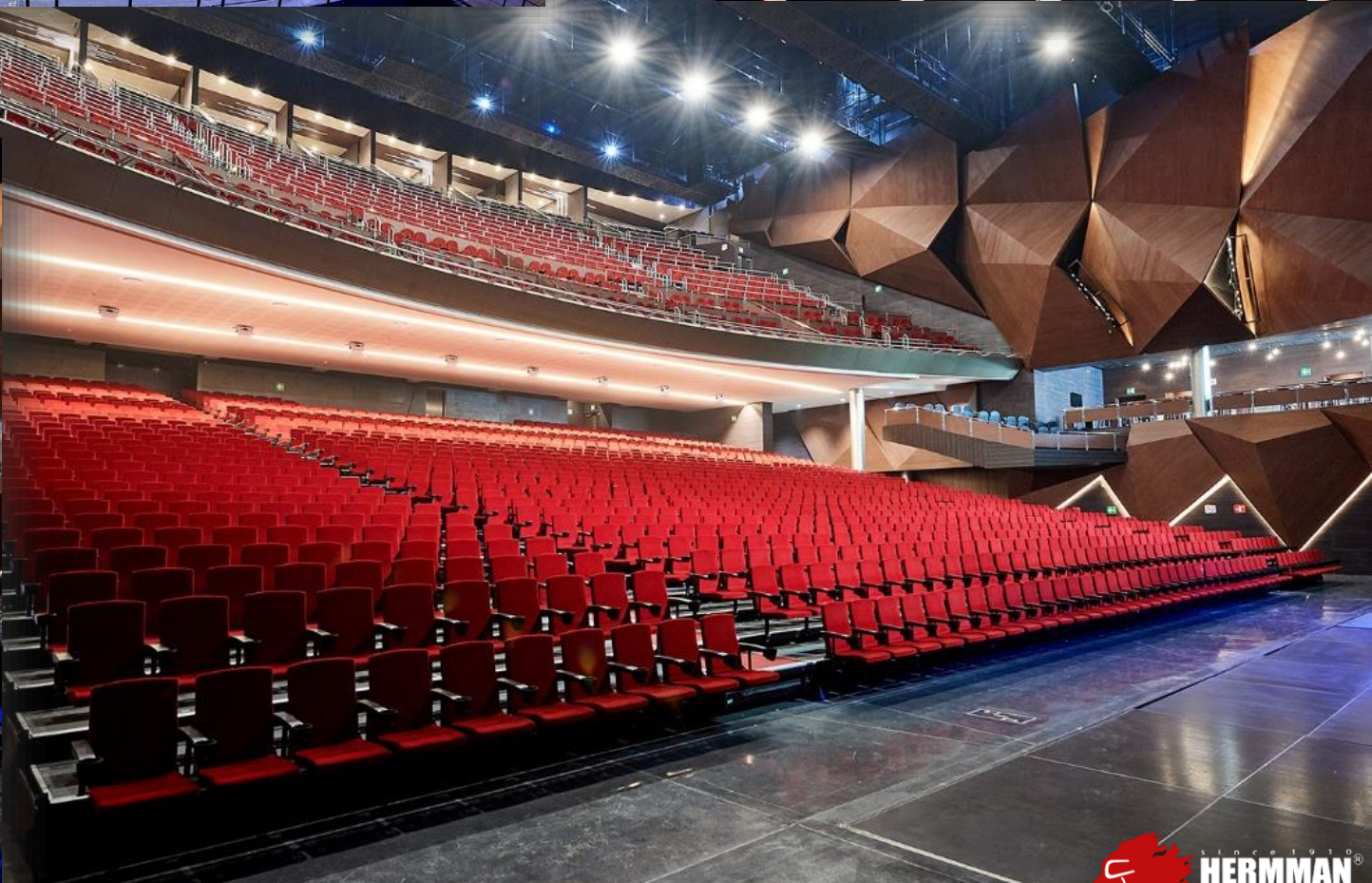

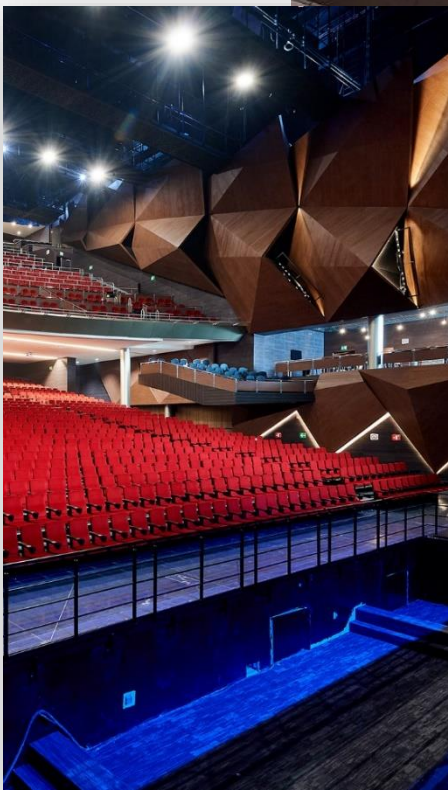

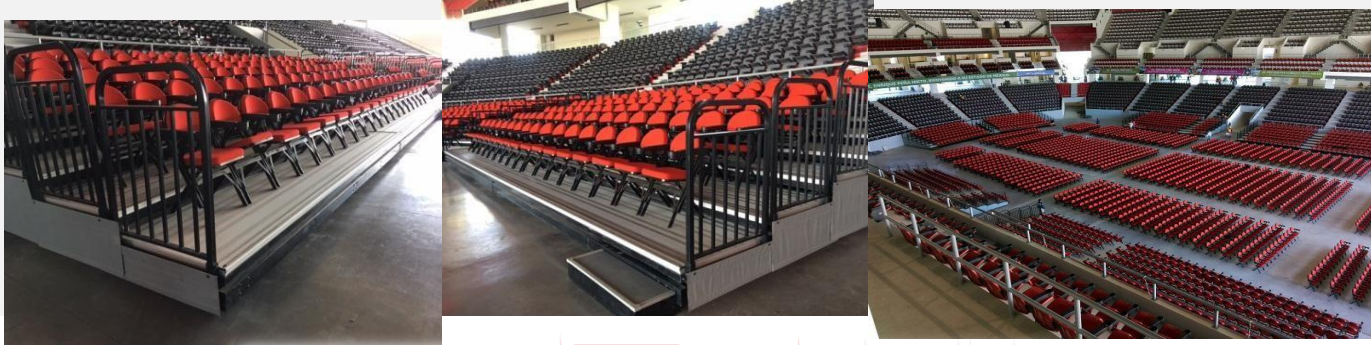

BABILONIK



HERMAN Luxe
Lider Nacional en Mobiliario



WWW.BABILONIK.COM

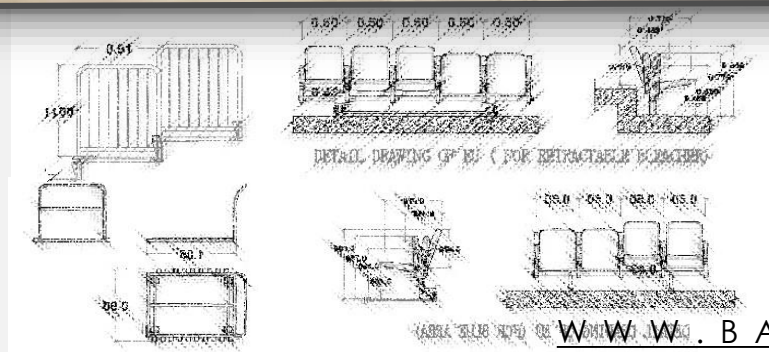
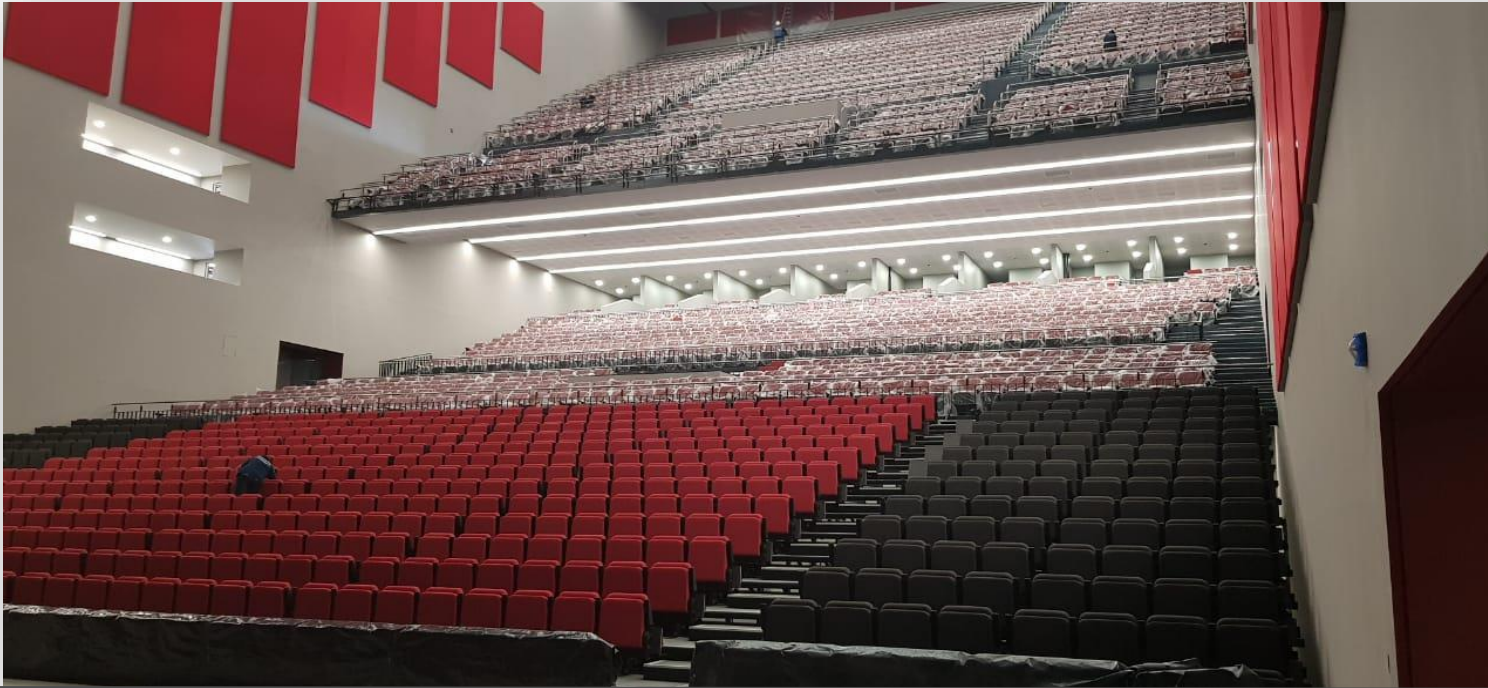

DETAIL DRAWING OF CHAIR FOR RETRACTABLE BORMCHERY



BABILONIK



**HERMANN[®]
Luxe**
Lider Nacional en Mobiliario

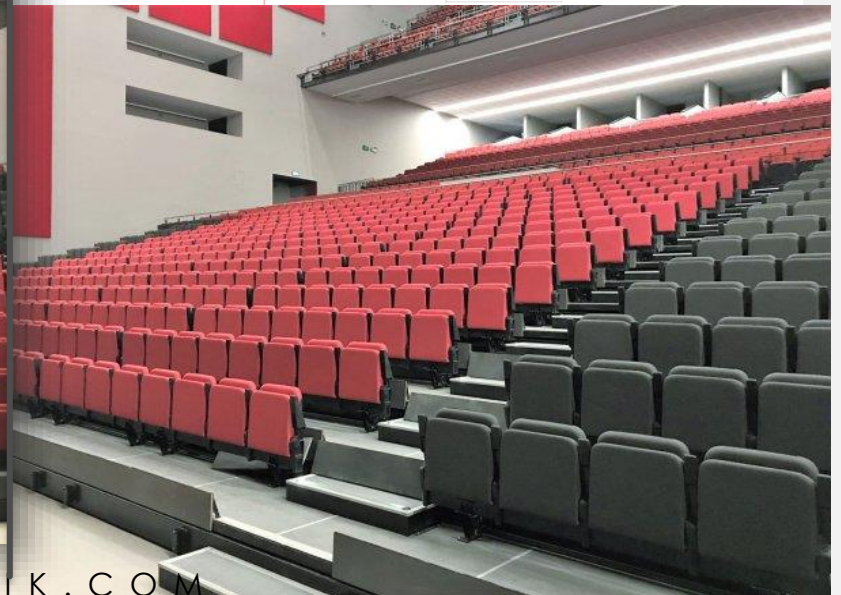



www.babilonik.com

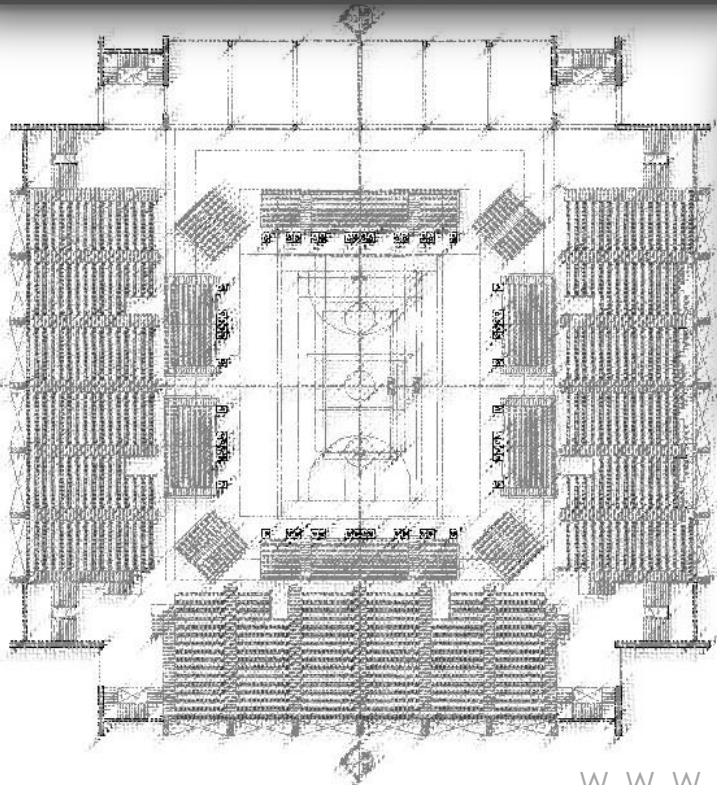

WWW.BABILONIK.COM



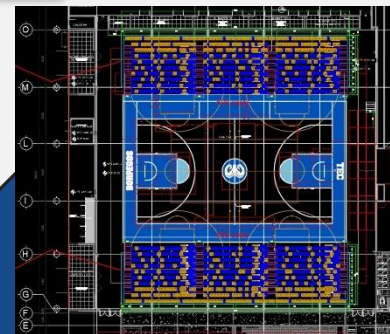

BABILONIK

HERMMAN Luxe
Lider Nacional en Mobiliario

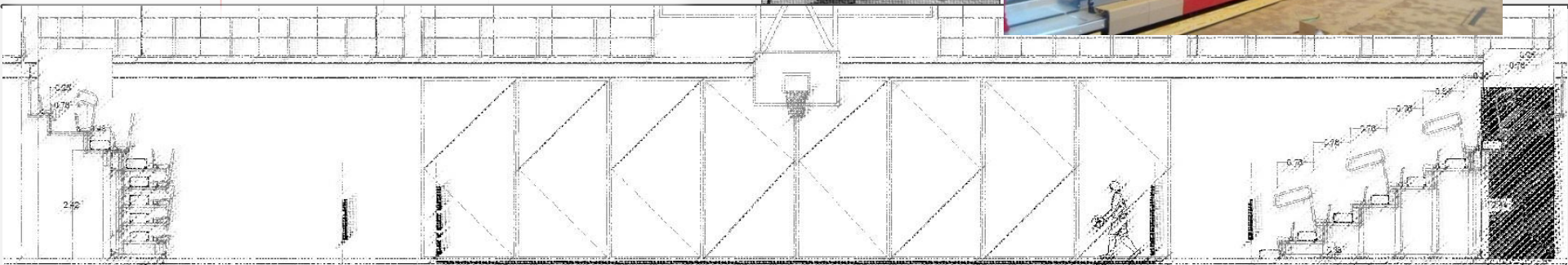
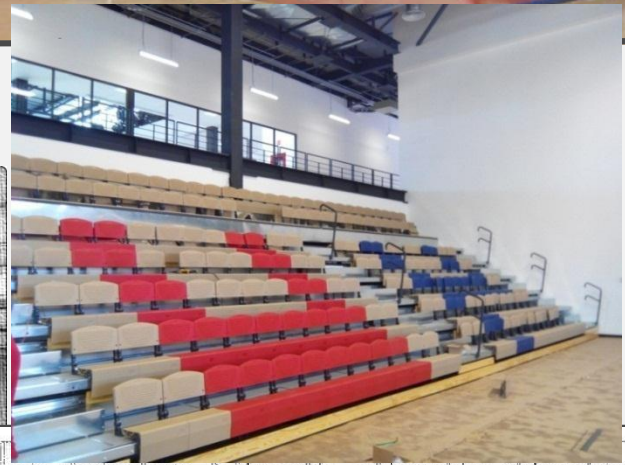
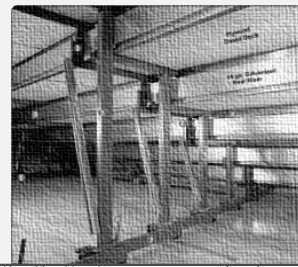
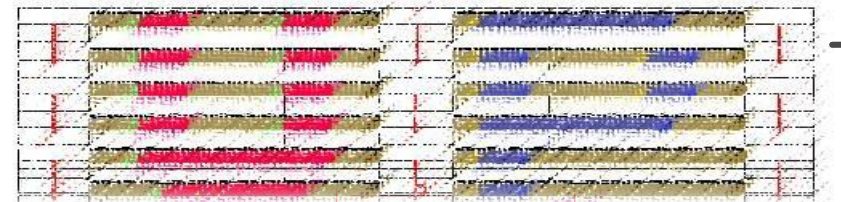

WWW.BABILONIK.COM

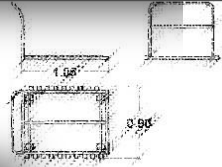
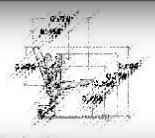
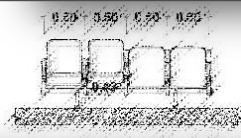
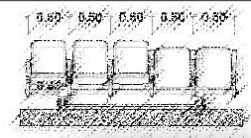
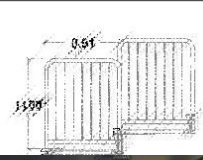
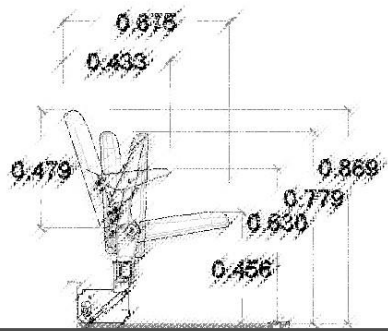



DETAIL DRAWING OF 10' (FOR RETRACTABLE SCENERY)

DETAIL DRAWING OF 20' (FOR BLUE AREA)





SECCION A

WWW.BABILONIK.COM

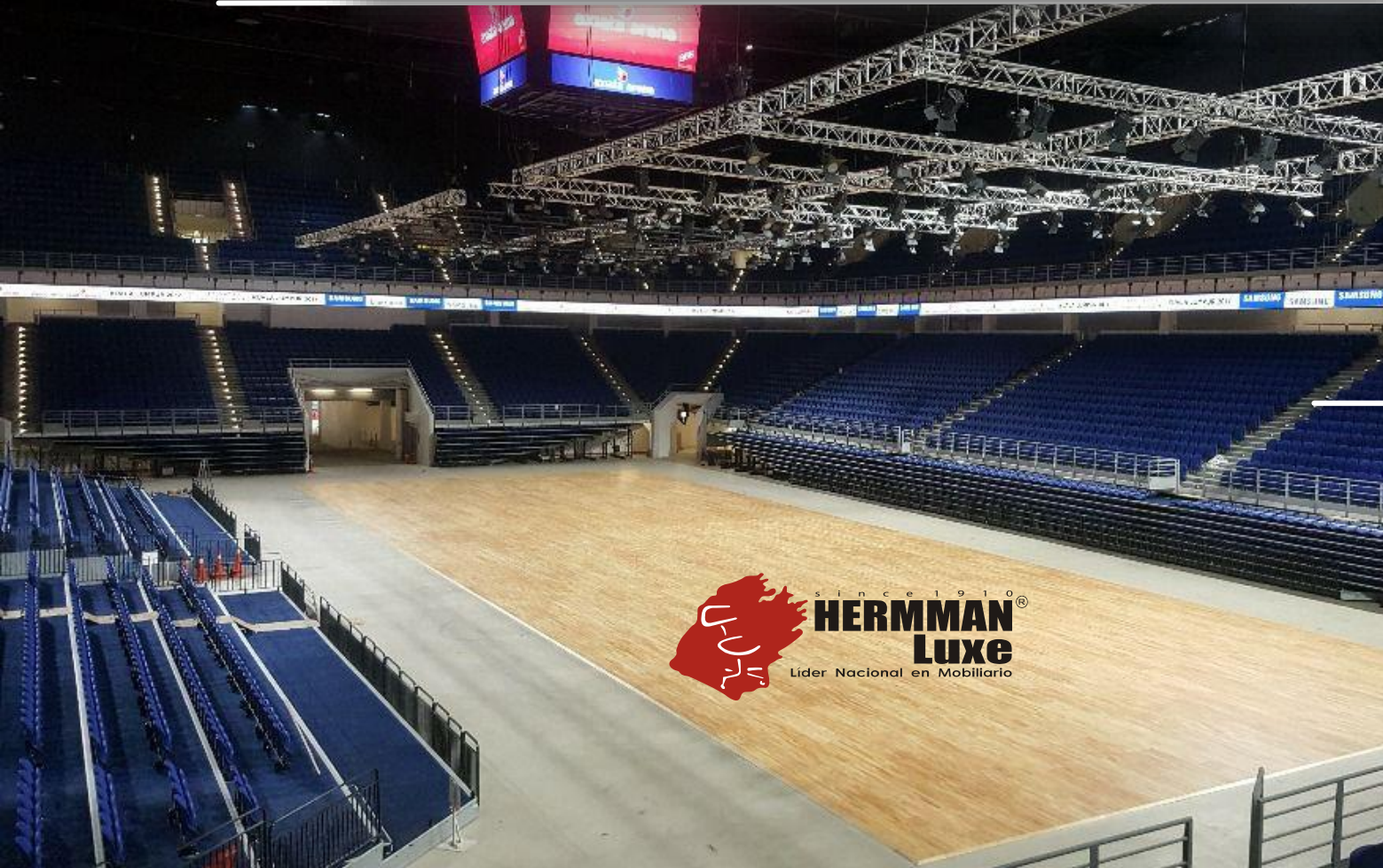
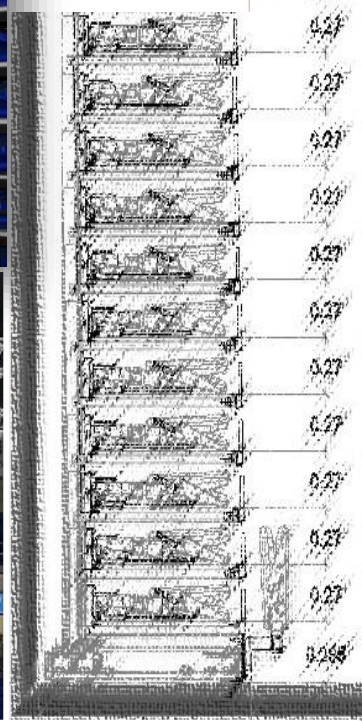
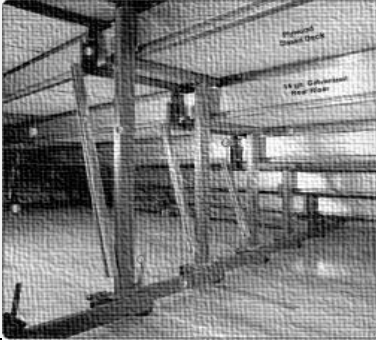



BABILONIK



HERMMAN Luxe
Lider Nacional en Mobiliario

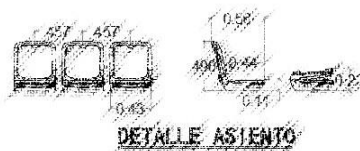
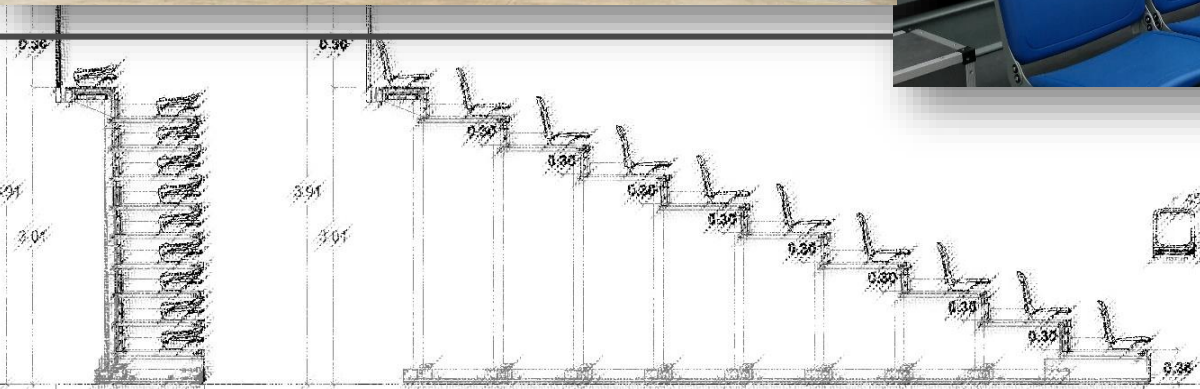

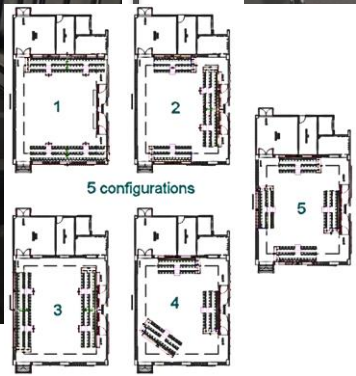
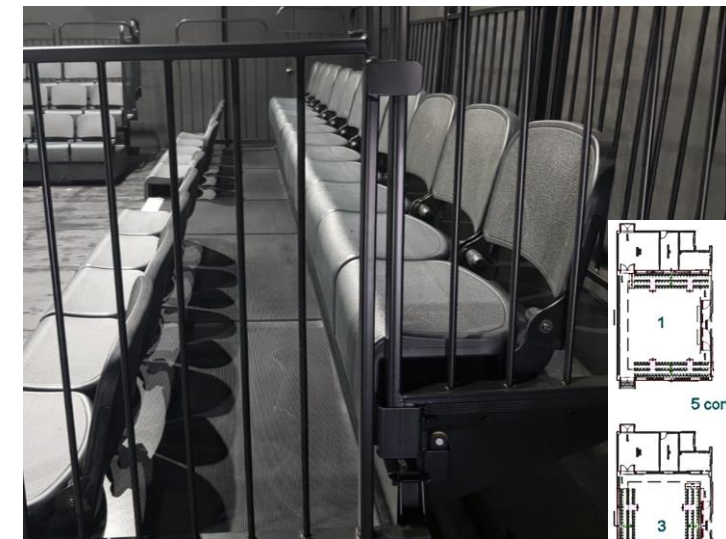
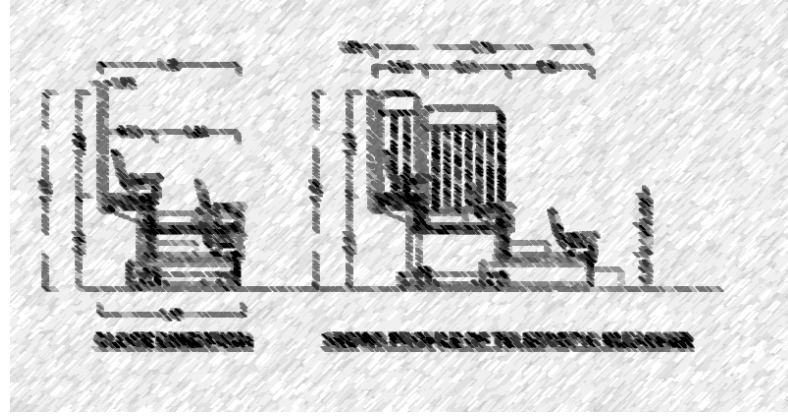
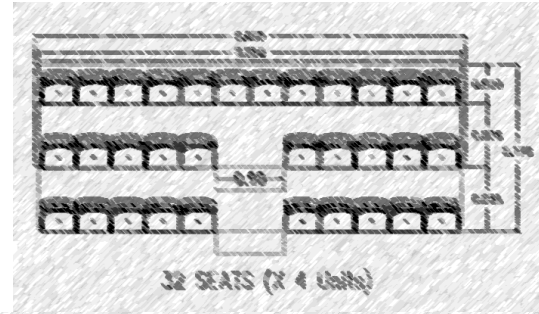

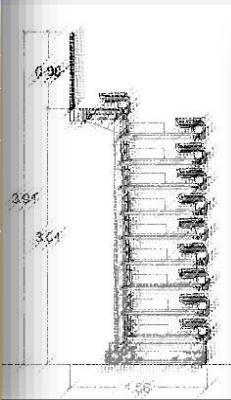
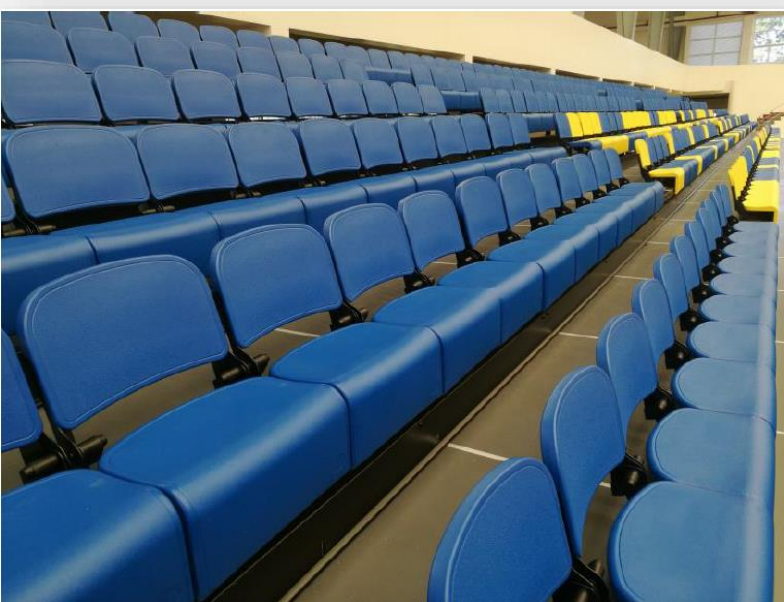



BABILONIK

 **HERMMAN[®] Luxe**
Lider Nacional en Mobiliario

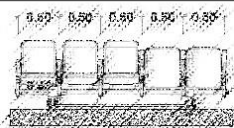
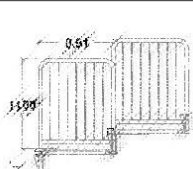
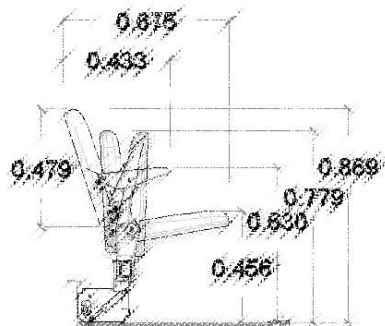

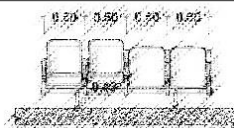
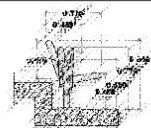

DETAIL DRAWING OF 20" (FOR RETRACTABLE SEATING)



DETAIL DRAWING OF 20" (FOR BLUE AREA)

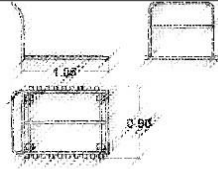

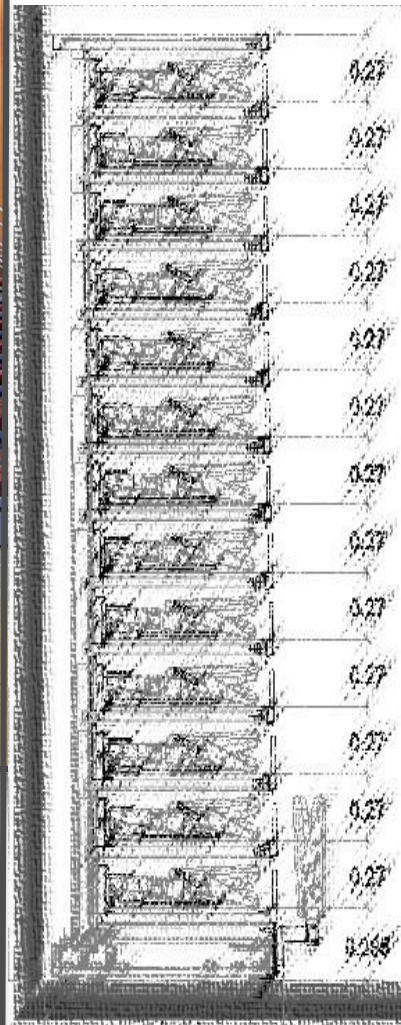
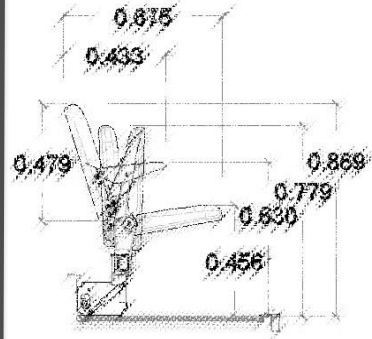
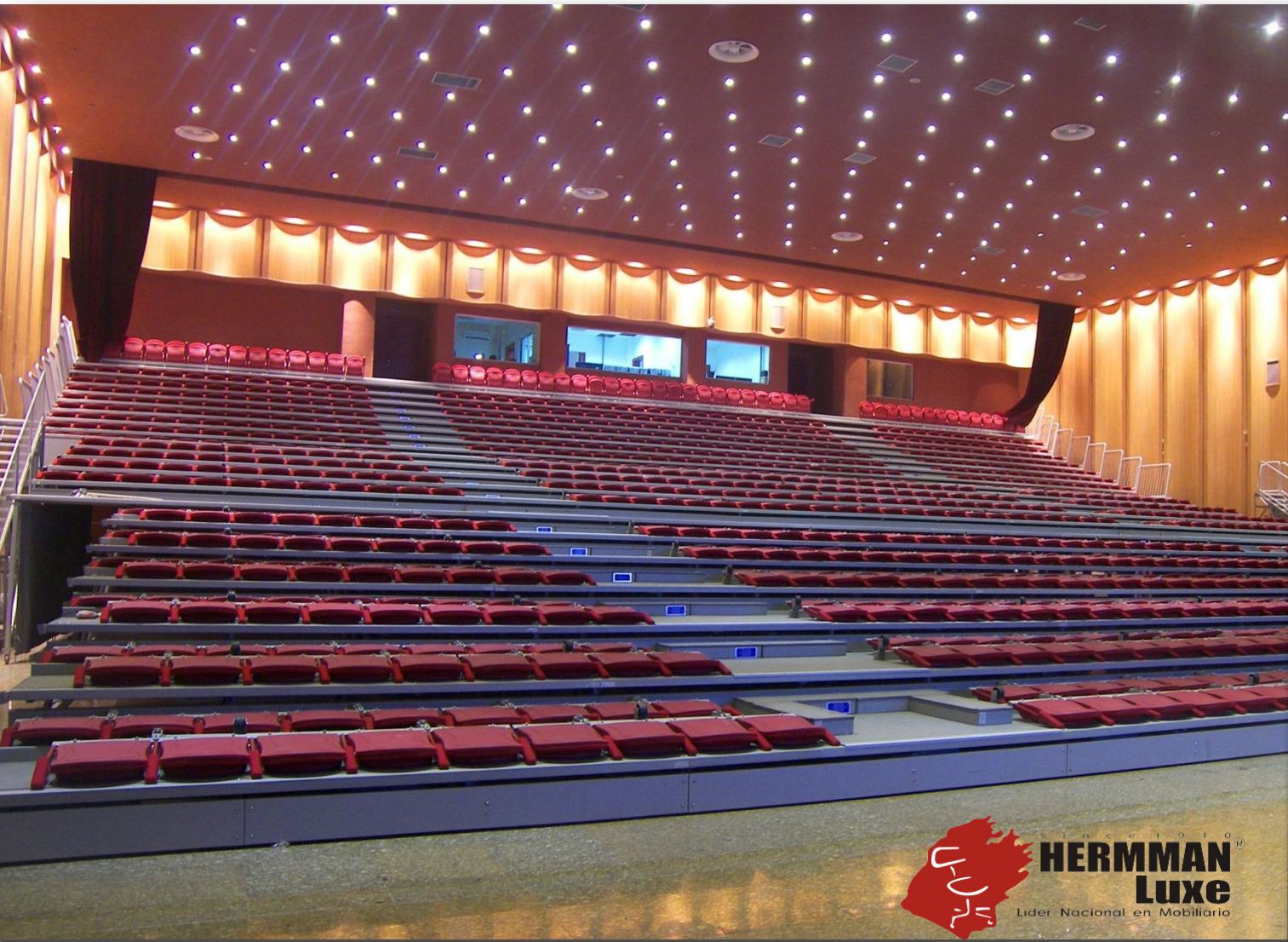

WWW.BABILONIK.COM

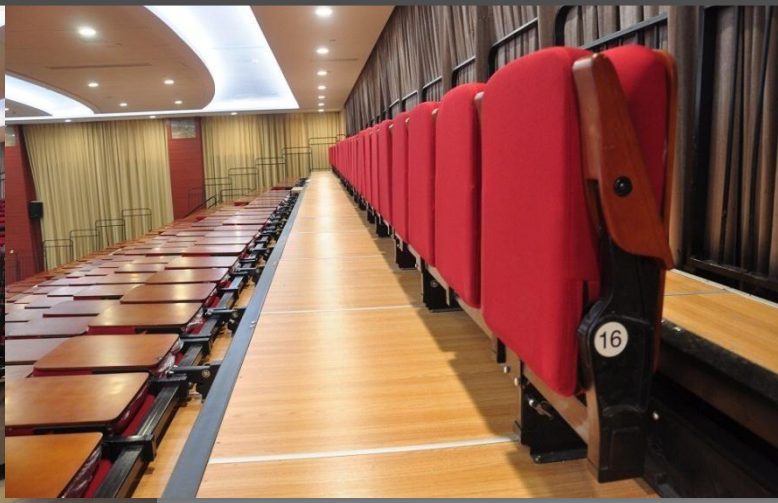
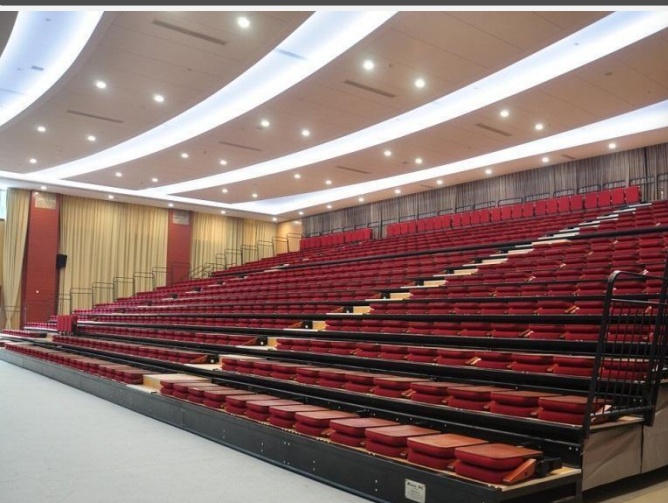
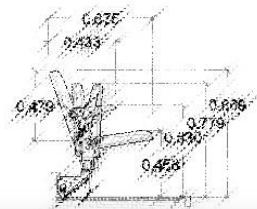
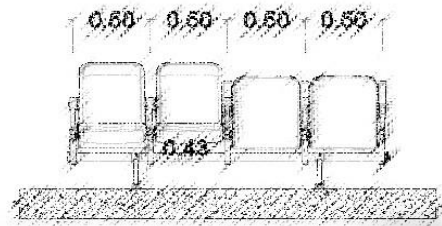

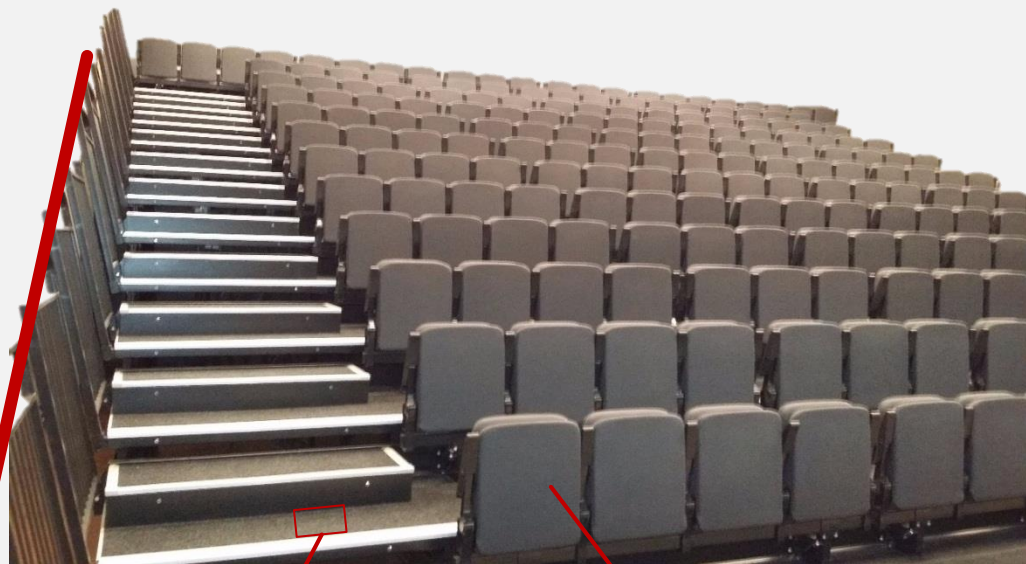

Piso de Plywood en 18mm con recubrimiento en PVC de uso rudo o el acabado de su preferencia.



Butaca retráctil expuesta a los estándares de calidad mas estrictos.

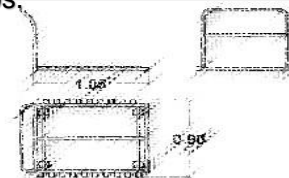
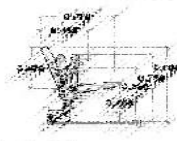
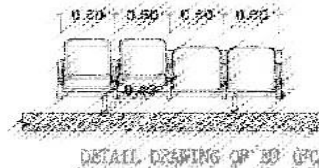
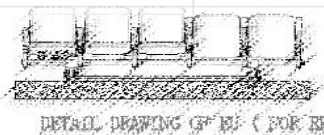
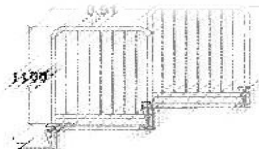



BABILONIK



Soporte y rodamiento ajustable entre cada viga principal que permite un desplazamiento mas suave además de asegurar la posición correcta de la grada.

Sistema de Motores independientes que pueden cambiar de modo eléctrico a modo manual.



Estructura diseñada con soportes verticales e inclinados para la barra horizontal de cada fila permitiendo soportar mayor carga en la superficie de nuestras gradas.



Sistema con ruedas continuas montadas de manera oculta en guía de metal reforzado para reducir ruidos al ser operada.



Sistema de Auto-Bloqueo automático que permite una suave operación, activando cada una conforme se despliega la grada.



Perfil de aluminio en peraltes con tiras fluorescente para seguridad del usuario.

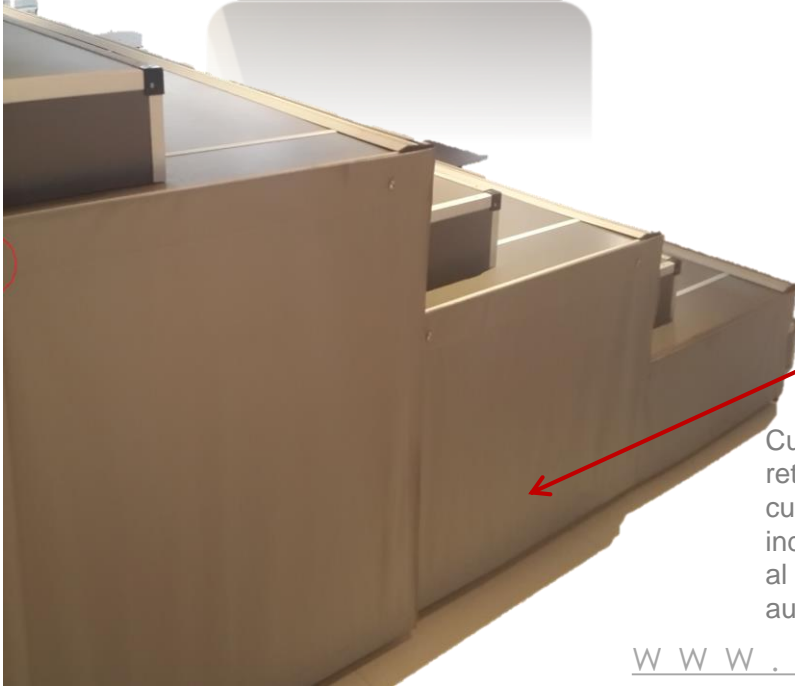

Cubiertas laterales con retardante al fuego, cada fila cuenta con una cubierta independiente permitiendo que al operar la grada estas sean auto almacenadas.



Escalones terminados en aluminio y esquinas con tapas plásticas sin filo.